

Imp Price List 2008

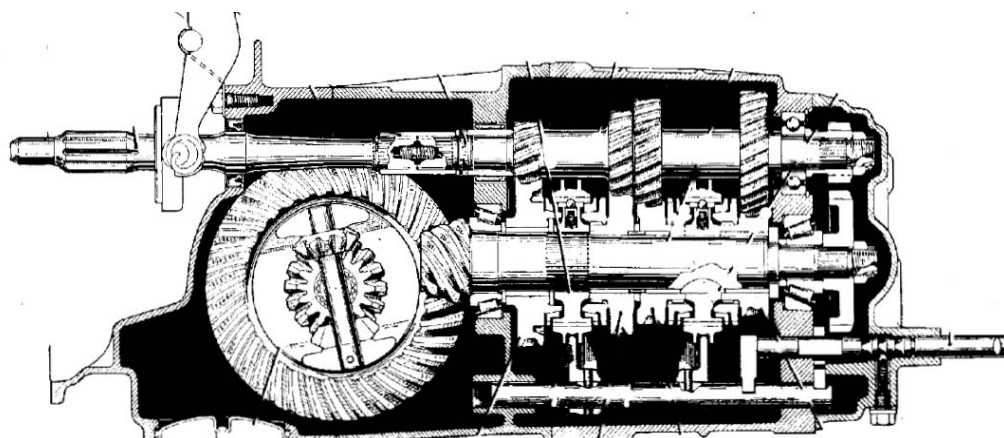

Tel: 0845680 1952
Email: info@jackknight.co.uk
Web: www.jackknight.co.uk

Performance Transaxles and Gearkits for Race, Rally and High Performance Road. 4 and 5 speed dog engagement with a choice of ratios



Gearboxes and Gearkits

JKDIM4	4 Speed Straight Cut Dog Gearset Kit Ratios to be selected from the ratio list	£1,500.00
JKDIM5	5 Speed Straight Cut Dog Kit Gearset Kit Ratios to be selected from the ratio list	£1,800.00
JKDRE4/5	Gearbox rebuild	£450.00
JKDIMC4	Gearbox rebuild using a new 4 Speed Straight Cut Dog Gearset (using customer donor gearbox)	£1,900.00
JKDIMC5	Gearbox rebuild using a new 5 Speed Straight Cut Dog Gearset (using customer donor gearbox)	£2,200.00
Special Offers		
JKD4PC1	4 Speed Straight Cut Dog Gearset, rebuilt in your gear case plus either a Friction Plate LSD or Cam and Pawl LSD	£2,450.00
JKD5PC2	5 Speed Straight Cut Dog Gearset, rebuilt in your gear case plus either a Friction Plate LSD or Cam and Pawl LSD	£2,650.00
New for 2008 season Sequential Pro-shift System for the 4 and 5 speed gearboxes		
Sequential	Sequential Pro-shift System	£695.00
	Auto Clutch Control	£220.00
	Paddle Steering Wheel Mount System	£230.00

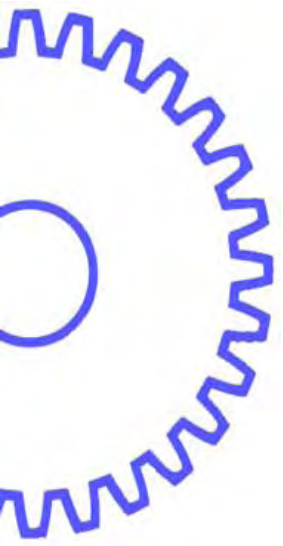

High Quality Gears. 4 and 5 speed dog engagement with a choice of ratios



Individual Gears & Ratios

Gear	Compound Ratio	Driveshaft/Pinion Shaft	Individual Ratio	Price per gear set
1st	16.54	13/44	3.843	£285.00
	13.56	12/34	3.666	£285.00
	12.75	13/34	3.616	£285.00
	11.50	14/33	3.516	£285.00
	10.35	15/32	3.416	£285.00
	10.65	15/33	3.446	£245.00
	9.70	16/32	3.344	£245.00
	9.30	16/31	3.316	£245.00
	8.87	17/31	3.216	£245.00
	8.55	17/30	3.216	£245.00
	7.80	18/29	3.116	£245.00
	7.55	18/28	3.066	£245.00
	7.15	19/28	3.016	£245.00
	6.90	19/27	2.966	£245.00
	6.55	20/27	2.916	£245.00
	6.30	20/26	2.866	£245.00
	6.00	21/26	2.816	£245.00
	5.77	21/25	2.766	£245.00
	5.53	22/25	2.716	£245.00
	5.30	22/24	2.666	£245.00
	5.05	23/24	2.566	£245.00
	4.85	23/23	2.566	£245.00
	4.65	24/23	2.566	£245.00
	4.40	24/22	2.532	£265.00
	4.27	25/22	2.396	£265.00
	4.07	25/21	2.396	£265.00
	3.90	26/21	2.396	£265.00



Limited Slip Differentials



High Quality Differentials

Friction Plate – Road and Competition

Cam & Pawl – Competition – Full Race



Friction Plate Type LSD		
JKD0380IM	Complete Assembly	£539.00
Parts		
01007IM	Cross Pin	£40.17
03806IM	Friction Disc (each)	£18.15
03807IM	Clutch Plate (each)	£18.15
03820IM	Side Gear	£33.00
03821IM	Planet Gear	£35.00
03822IM	Side Gear Ring	£85.00
03830IM	Cover	£165.00
03831IM	Plate	£110.00

Cam & Pawl Type LSD		
JKD004IM	Complete Assembly	£645.00
Parts		
IM01142	Cover	£114.59
IM02142	Cage	£202.61
IM03142	Inner Cam	£176.50
IM04142	Outer Cam	£201.22
IM061A42	Pawl (each)	£15.08

SPECIAL OFFER	
Differential Rebuild/Service (Labour Only)	£100.00



Driveshafts & Steering



Competition Steering



Steering		
JKDIMQR	Quick Rack and Pinion	£325.00
JKDSAA	Steering Assembly Aluminium	£450.00
JKDSAM	Steering Assembly Magnesium	£680.00
JKDEPASIM	Power Steering Kit	£1,200.00
JKDIMSR	Rack refurbishment	£160.00
JKDSIMV	Variable Steering Kit	£540.00



Competition Driveshafts		
JKDIMOS	Competition Output Shaft	£225.00
JKDIMDS	Competition Driveshaft	£245.00



Steering Components		
JKD IMUJ	Universal Joint	£75.00
JKDIMM	Male end 3/16 Spline	£45.00
JKDIMF	Female end 3/16	£42.40

PRESS RELEASE

Changing gear has never been so easy **Benefits:**

Jack Knight are proud to announce a new gearshift system that converts the H pattern selection to a sequential shift arrangement



Jack Knight have been designing and manufacturing automotive components for over 50 years.

Combining the reliability of mechanical linkages and gear technology with the flexibility of electronics and software control. This system will offer a serious alternative to the sequential gearbox at a far lower price and without the problems some sequential gearboxes have had.

Designed and manufactured to the same exacting standards as our steering racks

The system will be supplied in a kit for installation and will replace the conventional gear lever. The design of the kit includes the JKD quickshift system making gearchange even quicker

- Robust system with less moving parts than the sequential alternative
- All components are manufactured 'In House'
- Product design underpinned by extensive validation and endurance programme.
- Competitively priced
- All work is supplied with a full 12month warranty.
- Optional steering wheel mounted Paddle switches and clutch control
- Constant high speed gear change
- Designed and manufactured to the same exacting standards as our steering racks

The kit can be fitted to RWD, FWD, 4WD including transaxles. Application suitable for race, rally, track day or general high performance use.

Combine this kit with a Jack Knight dogbox and LSD and you will have a truly race winning transmission at less than half the cost of an internal sequential alternative.

Jack Knight

Technology Centre
Camberley
Surrey
UK
GU15 3RN

Tel: 01276 500673

Email: info@jackknight.co.uk

Web: www.jackknight.co.uk

